

Total Forced Auto Stall (FAS) system

Bring White/Brown wire to ground to activate FAS1 relay. This relay latches FAS2, while opening the fuel injector wires.

Once the engine stops, release the ground, and FAS2 will keep the dc/dc enabled to allow 12V charging.

The clutch signal is made to look like it is pressed to eliminate the need to hold the clutch in.

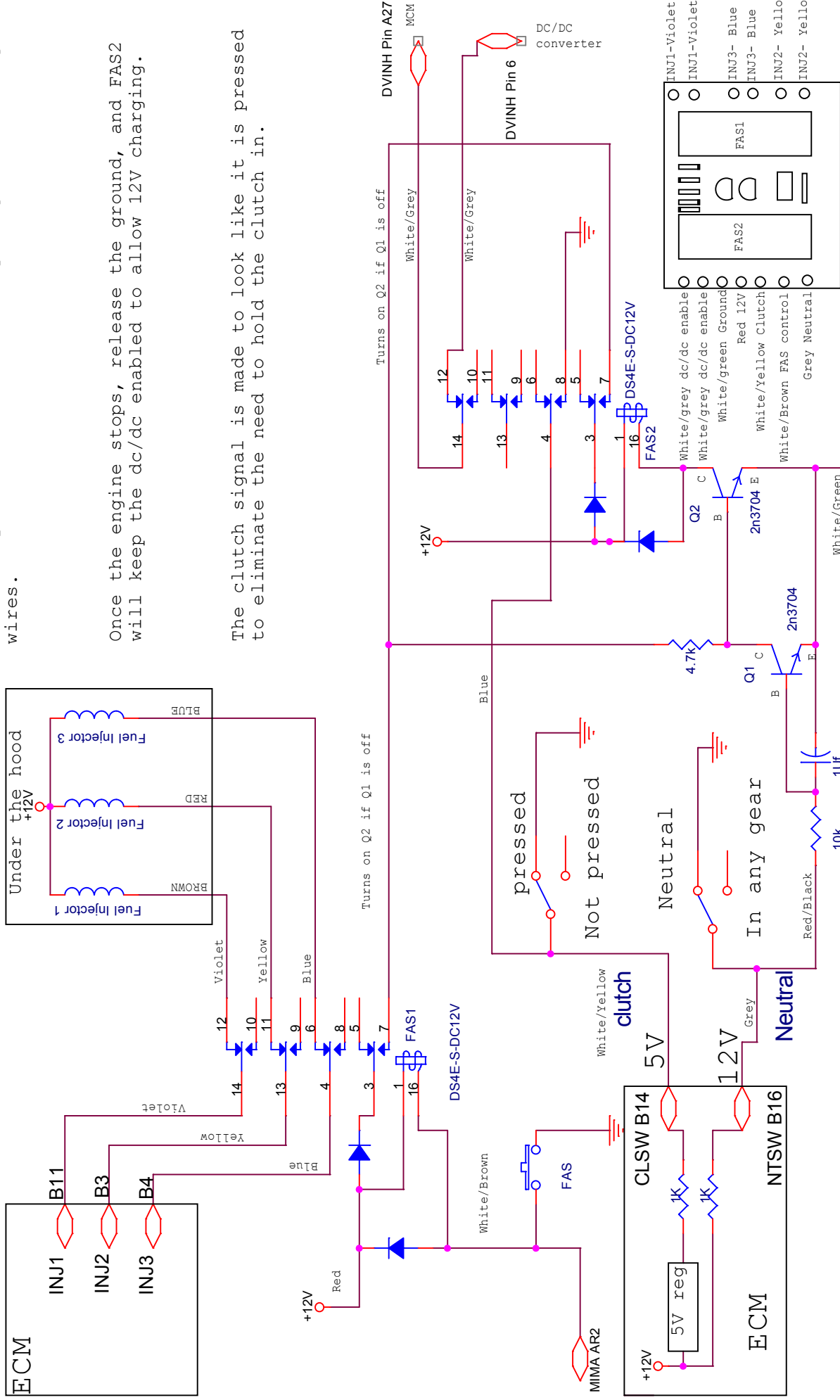

Title		Plug in harness FAS relay system	
Size		<Title> with DC/DC enable, and clutch hold	
Document Number	Rev	<Rev Code>	
Date:	Tuesday, March 03, 2009	Sheet	1 of 1